

### Technical data

dKLK 23   dKLK 23 CG-S <sup>1)</sup>	
Marking to 94/9/EC	Ⓔ II 2 G Ex d IIC T6 / Ⓔ II 2 D Ex tD A21 IP66 T80 °C
EC-Type Examination Certificate	PTB 04 ATEX 1017X
Permissible ambient temperature	-20 °C up to max. +45 °C (dept. on lamp power and operating position)
Rated voltage 1	230 V AC
Rated voltage 2	230 V DC
Rated current	max. 25 mA
Frequency	0 up to 50/60 Hz
Connecting terminals	flameproof inlet eXLink, 3pole, 2 + PE cage clamp terminal for cable Ø 8-11 mm and max. 1.5 mm <sup>2</sup> or flameproof cable gland M20 x 1.5 for cable Ø 8.5-16 mm; terminal L, N, PE max. 2.5 mm <sup>2</sup> clamp terminal
Insulation class	I
Lamp/Illuminant	Compact-fluorescent lamp with integrated electr. ballast, lamp cap E27, lamp power 5-8 W, manufacturer Philips MASTER PL Electronic 5W/8 W or equivalent; Flashmodule (see accessories)
Lamp cap	E 27
Rated luminous flux <sup>2)</sup>	approx. 400 lm (7/8 W)
Degree of protection accd. EN 60529	IP66
Dimensions (L x W x H)	164.5 x 189 x 128 mm
Weight	approx. 1.7 kg
Enclosure material	Glass-fibre reinforced polyester
Protective cover/protective bowl	Polycarbonat

### Accessory Flash module type Eurolite E27 Strobe

Rated voltage	230 V
Frequency	50 Hz
Rated power consumption	5 W
Flash frequency	1-3 Hz

<sup>1)</sup> For operation with CEAG emergency lighting systems, with code switch for 20 addresses

<sup>2)</sup> Depends on used lamps

Scope of delivery with fixing accessories and without lamp.

## | dKLK 23 | dKLK 23 CG-S |

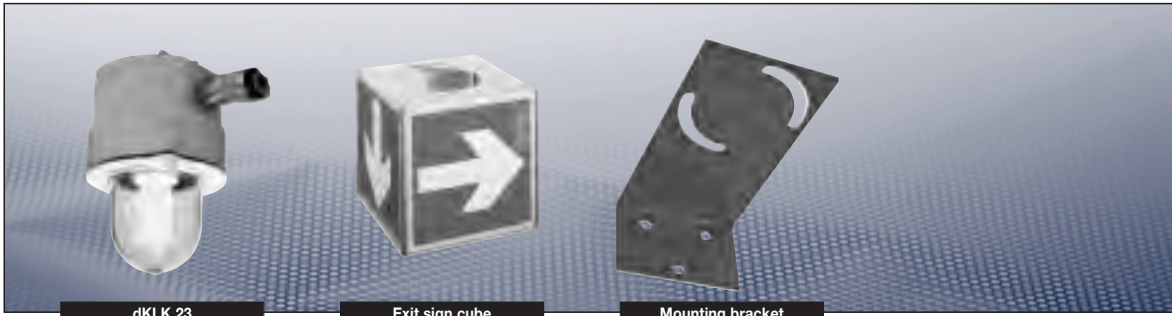

dKLK 23

Exit sign cube

Mounting bracket

### Ordering details

Type	Power connection	Colour of protective cover	Ordering Code
dKLK 23			
dKLK 23/eXLink	eXLink	clear	GHG 871 1001 R 0001
dKLK 23/eXLink	eXLink	red	GHG 871 1101 R 0001
dKLK 23/eXLink	eXLink	green	GHG 871 1201 R 0001
dKLK 23/eXLink	eXLink	blue	GHG 871 1301 R 0001
dKLK 23 CG-S <sup>1)</sup> /eXLink	eXLink	clear with CG-S-module and code switch	GHG 871 2001 R 0001
dKLK 23/EEEx d	Cable gland M20	clear	GHG 871 1001 R 0101
dKLK 23/EEEx d	Cable gland M20	red	GHG 871 1101 R 0101
dKLK 23/EEEx d	Cable gland M20	green	GHG 871 1201 R 0101
dKLK 23/EEEx d	Cable gland M20	blue	GHG 871 1301 R 0101
dKLK 23 CG-S <sup>1)</sup> /EEEx d	Cable gland M20	clear with CG-S-module and code switch	GHG 871 2001 R 0101

<sup>1)</sup> for connection to CEAG emergency supply systems, with address switch for 20 addresses.

Scope of delivery with wall mounting bracket and without lamp.

### Accessories

#### Ex-signal- and exit sign luminaire dKLK 23

Type	Ordering Code
Flash module Eurolite E27 Strobe	GHG 870 1912 R 0001
Exit sign cube (242 x 227 x 242 mm)	4 0071 344 115
Compact fluorescent lamp 7 W with EVG	GHG 870 9302 P 0002

### Dimension drawing | Polar curves

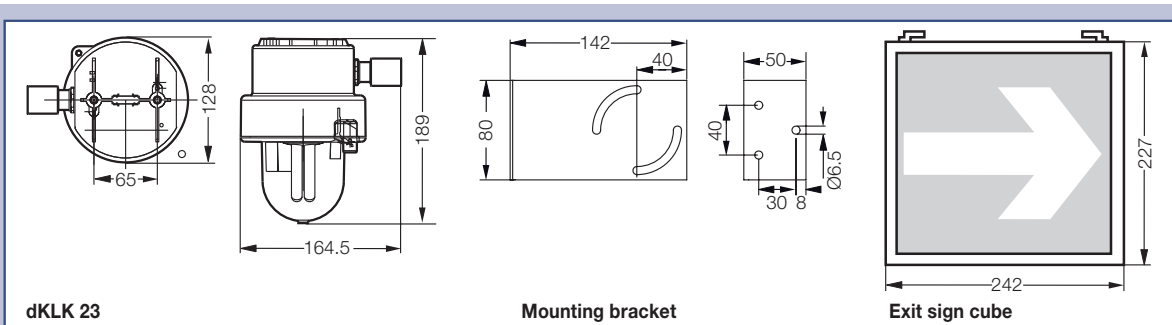

dKLK 23

Mounting bracket

Exit sign cube

#### Polar curve dKLK 23 / dKLK 23 CG-S

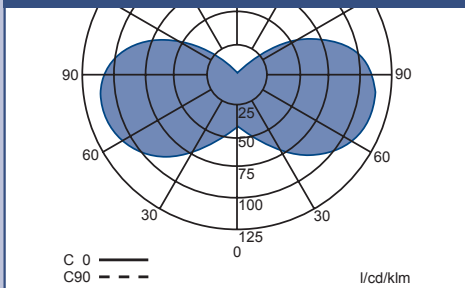

Dimensions in mm