

# PTF30 Series

## Features

- Best pressure transmission solution for small and middle sized project such as indoor heating and air conditioning, water and sewer, or incinerator, etc.
- Improves noise resistance and minimize effects by external disturbance
- Realizes high accuracy measurement by stainless steel diaphragm of pressure sensing part for various measured subjects
- 4-20mA analog output (2-wire)
- Various functions :  
User input range, display scale, output scale, digital filter, multi-display selection, error display, TUF (two unit function), etc.
- Explosion class : Ex d IIC T6 IP67

CE



 Please read "Caution for your safety" in operation manual before using this unit.

## Ordering information

PTF30 — G 6 N N — F8 (0 to 5 kgf/cm<sup>2</sup>)

①                      ②                      ③                      ④                      ⑤                      ⑥                      ⑦

Item	Description		
①Item	PTF30	Pressure Transmitter	
②Measurement pressure	G	Gauge pressure	
	A	Absolute pressure	
③Pressure range		Gauge pressure	Absolute pressure
	1	0 to 0.35kgf/cm <sup>2</sup>	0 to 0.35kgf/cm <sup>2</sup>
	2	0 to 1kgf/cm <sup>2</sup>	0 to 1kgf/cm <sup>2</sup>
	3	0 to 2kgf/cm <sup>2</sup>	0 to 2kgf/cm <sup>2</sup>
	4	0 to 7kgf/cm <sup>2</sup>	0 to 7kgf/cm <sup>2</sup>
	5	0 to 20kgf/cm <sup>2</sup>	0 to 20kgf/cm <sup>2</sup>
	6	0 to 35kgf/cm <sup>2</sup>	0 to 35kgf/cm <sup>2</sup>
	7	0 to 70kgf/cm <sup>2</sup>	—
	8	0 to 200kgf/cm <sup>2</sup>	—
	9	0 to 350kgf/cm <sup>2</sup>	—
	A	-257mmHg to 0kgf/cm <sup>2</sup>	—
	C	-760mmHg to 0kgf/cm <sup>2</sup>	—
	F	-760mmHg to 2kgf/cm <sup>2</sup>	—
	H	-760mmHg to 7kgf/cm <sup>2</sup>	—
	M	-760mmHg to 20kgf/cm <sup>2</sup>	—
O	-760mmHg to 35kgf/cm <sup>2</sup>	—	
Z	Others	—	
④HART communication output	N	None	
⑤Communication output	N	Without bracket	
	B	With bracket	
⑥Pressure port	F8	PF 3/8	
⑦User pressure range		User pressure range *1	

※1: Write the desired pressure range and it is the default of user pressure range.(③ Select "Z" at pressure range)

# Standard Pressure Transmitter

## Dimensions

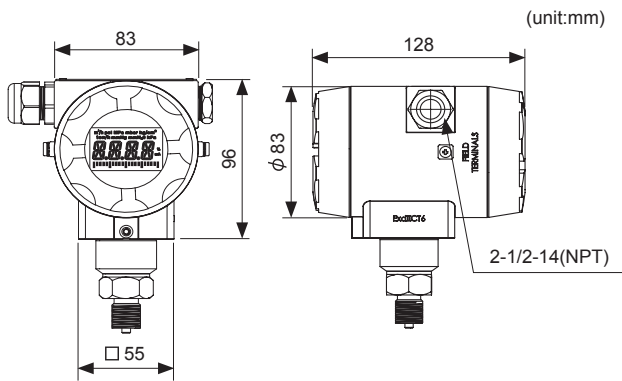

### • Mounting bracket

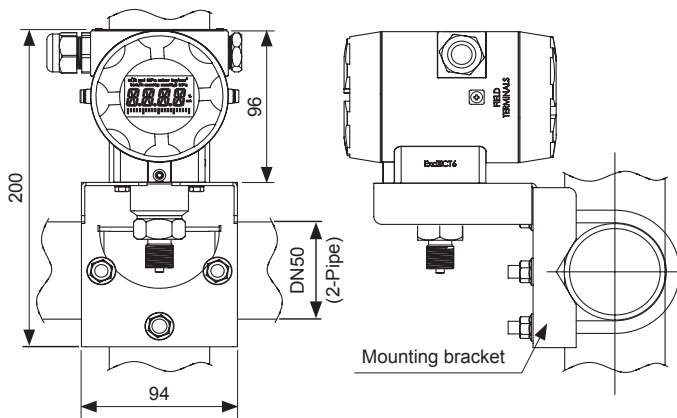

## Connections

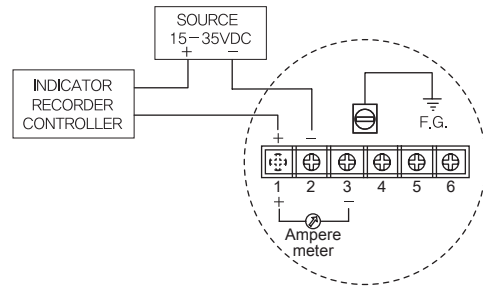

※ You can check 4-20mA output by connecting an ampere meter. (impedance: max. 30Ω)

## Specifications

Series	PTF30	
Measured materials	Vapor, Liquid, Fluid (except corrosive environment of SUS316)	
Power supply	15-35VDC	
Display method	4 digit 12 Segment LCD Display	
Character size	W 6.24×H10.73mm (12 Segment) / W1.45×H2.5mm (unit)	
Output	DC4-20mA 2-wire Low-limit : 3.6mA(-2.5%), High-limit : 21.6mA (+10%)	
Accuracy <sup>*1</sup>	<ul style="list-style-type: none"> <li>• 10% of Span &lt; URL: <math>\pm(0.05 + 0.015 \text{ URL}/\text{Span})\%</math> of Span</li> <li>• 10% of Span <math>\geq</math> URL: <math>\pm 0.2\%</math> of Span</li> </ul>	
Temperature characteristics	At 20°C, $\pm(0.075\% \times \text{URL} + 0.15\% \times \text{Span})$	
Setting method	Setting by front push keys	
Sampling cycle	300ms	
Dielectric resistance	1000VAC for 1 min. (between external terminal and case)	
Vibration	0.75mm amplitude at frequency of 5 to 55Hz (for 1 min.) in each of X, Y, Z directions for 2 hours	
Insulation resistance	Min. 100MΩ (at 500VDC megger)	
Noise resistance	Square shaped noise by noise simulator (pulse width 1μs)±240V	
Memory protection	Approx. 10 years (non-volatile semiconductor memory type)	
Environment	Ambient temperature	-20 to 70°C, storage: -20 to 80°C
	Ambient humidity	0 to 85%RH
Material	Body : Aluminum(AIDc.8S), Cover O-Ring : Buna N, Diaphragm : SUS316, Connections : SUS316	
Explosion class <sup>*2</sup>	Ex d IIC T6 IP67	
Approval	CE	
Unit weight	1.2kg	

※ 1. Span: User pressure range[L - P G to H - P G]  
URL: Pressure range by model

※ 2: This Explosion class is acquired and managed by Konics Co., Ltd.

※ Environment resistance is rated at no freezing or condensation.

A. Recorder  
B. Indicator  
C. Converter  
D. Controller  
E. Thyristor unit  
F. Pressure transmitter  
G. Temp. transmitter  
H. Accessories

TPS20  
KT-302H  
PTF30

# PTF30 Series

## Part descriptions

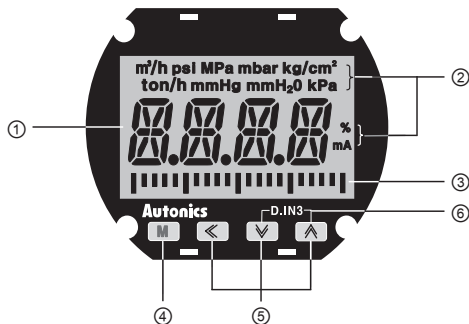

- ① Display part: Displays detected pressure value, several setting value and errors.
- ② Unit display part: Displays the currently set input unit.
- ③ Output scale bar graph: Displays output 4-20mA as scale bar graph by 5% unit.
- ④ **M** key: Used to enter parameter mode, move parameters and save SV.
- ⑤ **←**, **↵**, **↑** key: Used to enter parameter set mode, move digits.
- ⑥ D.IN3 : Press the **↵** and **↑** keys at the same time for 3 sec., the set function (display HOLD, zero-point adjustment) at  $dI - k$  in parameter.

## Pressure conversion chart

	gf/cm <sup>2</sup>	kgf/cm <sup>2</sup>	Pa	kPa	MPa	mbar	bar	mmH <sub>2</sub> O	psi	mmHg
1gf/cm <sup>2</sup>	1	0.001000	98.0665	0.0980665	0.000098	0.980665	0.000981	10.00000	0.014223	0.735559
1kgf/cm <sup>2</sup>	1000.000	1	98066.50	98.06650	0.098067	980.665	0.980665	10000.00	14.22334	735.5592
1Pa	0.010197	0.0000102	1	0.001000	0.000001	0.01	0.000010	0.101972	0.000145	0.007501
1kPa	10.19716	0.010197	1000.000	1	0.001000	10	0.010000	101.9716	0.145038	7.500617
1MPa	10197.16	10.19716	1000000	1000.000	1	10000	10.00000	101971.6	145.0378	7500.617
1mbar	1.019716	0.0010197	100.0000	0.100000	0.000100	1	0.001000	10.19716	0.014504	0.750062
1bar	1019.716	1.019716	100000.0	100.0000	0.100000	1000	1	10197.16	14.50377	750.0617
1mmH <sub>2</sub> O	0.100000	0.000100	9.80665	0.009807	0.0000098	0.0980665	0.000098	1	0.001422	0.073556
1psi	70.30699	0.070307	6894.757	6.894757	0.006895	68.94757	0.068948	703.0696	1	51.71493
1mmHg	1.359510	0.001360	133.3224	0.133322	0.0001333	1.333224	0.001333	13.59510	0.019337	1

## Factory default

Parameter	Default	Parameter	Default	Parameter	Default	Parameter	Default
UNI E	bAR	L-SC	0000	L.oUt	0000*1	dSP1	PV
L-RG	0000*1	H-SC	1000	H.oUt	0350*1	dSP2	PV
H-RG	0350*1	ZERo	000	MAR.F	04	tUF	oFF
dP	0350*1	SPRN	1000	dI -k	HoLd	LoCK	oFF

※ 1. Defaults are different by the pressure range by each model.

## Functions

### Input unit [UNI E]

You can select input unit.  
( bar, mbar, Pa, kPa, MPa, gf/cm<sup>2</sup>, kgf/cm<sup>2</sup>, mmH<sub>2</sub>O, psi, mmHg, %, OFF )

### User input range [L-RG, H-RG]

Even though each unit has the range, you can set user input range within the pressure range when input range is limited for actual usage.

### Decimal point setting [dP]

This function is to change decimal point digit for input display value.

When input unit is set as % [°/°] or OFF [oFF], only the display position of decimal point is moved.

- Set range : 0 / 0.0 / 0.00 / 0.000

※ Set range is different by the pressure range.

### Display scale [L-SC, H-SC]

This function is to set (-1999 to 9999) for particular high/low limit value in order to display high/low limit value of measurement input. If measurement inputs are 'a' and 'b' and particular values are 'A' and 'B', it will display a=A, b=B as below graphs.

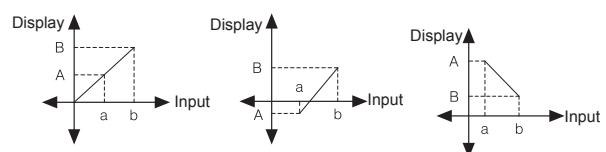

※ This function is available only when input unit is % [°/°] or OFF [oFF].

# Standard Pressure Transmitter

## Zero-point correction [ZER0]

It corrects the error of display value for 0% input.

- Set range : -999 to 999

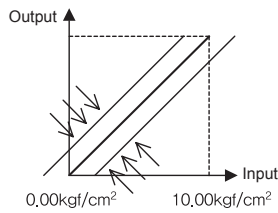

## Slope correction [SPAN]

It corrects the error of display value for 100% input.

- Set range : 0.900 to 1.100

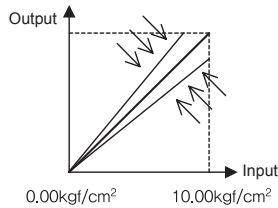

## Output scale [L0UT, H0UT]

For 4-20mA current output, this function is set to display value for current output.

Set the display value for 4mA [L0UT] and the display value for 20mA [H0UT].

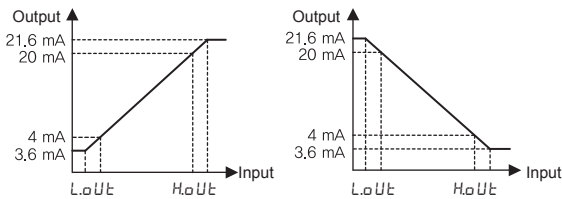

## Digital filter [MAVF]

Digital filter is able to display stably and output the noise from input line and irregular signals. This unit applies moving average digital filter and display cycle is same.

- Set range : 01 to 16

※ when setting as 01, digital filter function does not run.)

## Digital input [dl - k]

By front keys operation (D.IN3:  $\checkmark$  +  $\boxtimes$  for 3 sec.), one of two functions executes as the below table.

Function		Operation
H0Ld	Display HOLD	Temporarily indicated value is stopped in order to confirm indicated value in unstable input.
Z - tM	Zero-point adjustment	It is same function as [ZER0]. When executing this function, you can check and change correction value at ZER0.

## Multi-display selection [dSP1, dSP2]

Select one for display 1 and display 2 among PV, 0UT, LPEK, HPEK. Set dSP1 and dSP2 differently and it displays two different values in turn for 2 sec. When selecting LPEK (HPEK), the left (or the right) of output scale bar graph flashes for 0.5 sec.

## High/Low peak monitoring [LPEK, HPEK]

This function is to save high/low peak to check the invisible abnormal condition of system. Select this function display selection [dSP1, dSP2] parameter.

When the high/low peak is out of the temperature range, it displays HHHH or LLLL.

To initialize high/low peak, press the  $\checkmark$ ,  $\boxtimes$  keys at the same time for 3 sec. at [HPEK] or [LPEK].

In this case, peak value is the present input value.

## Two Unit Function [LUF]

For compound pressure model, this function displays the input pressure which is below atmospheric pressure by mmHg unit. It displays the input pressure atmospheric pressure or over atmospheric pressure by the set pressure unit.

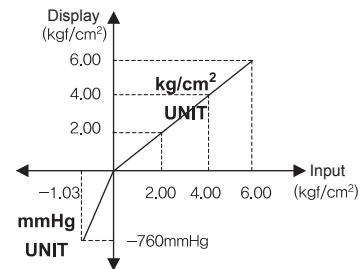

## Lock [L0CK]

It limits to check parameter set value and to change it.

	oFF	L0C1	L0C2
Parameter	●	◐	○

- : Enable to check/set, ◐: Enable to check, disable to set, ○: Disable to check/set

※ In L0C2, only the L0CK parameter displays.

## Parameter initialization [INI]

To initialize all parameter as factory default, supply the power to the product with pressing the [M] key and  $\boxtimes$  key at the same time and it enters initialization parameter.

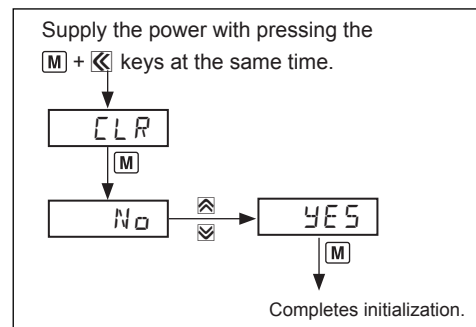

## Error

Display	Descriptions	Troubleshooting
HHHH	Flashes when measured pressure is higher than the 'pressure range'.	Adjust measured pressure within the 'pressure range'.
LLLL	Flashes when measured pressure is lower than the 'pressure range'.	Adjust measured pressure within the 'pressure range'.
ERR	Flashes when there is error to SV	Re-set it after checking the setting conditions

A. Recorder
B. Indicator
C. Converter
D. Controller
E. Thyristor unit
F. Pressure transmitter
G. Temp. transmitter
H. Accessories

TPS20
KT-302H
PTF30

# PTF30 Series

## Parameters

**RUN mode**

[M]

Input unit

UNIT

[S] ※1

BAR

[M] ※3

Low-limit input value

※4 L-RG

[S]

----

[M]

High-limit input value

※4 H-RG

[S]

----

[M]

Decimal point position

※4 d.P

[S]

----

[M]

Low-limit scale value

L-SC

[S]

0000

[M]

High-limit scale value

H-SC

[S]

1000

[M]

Zero-point correction

ZERO

[S]

000

[M]

Slope correction

SPAN

[S]

1.000

[M]

Low-limit output scale value

※4 L.OU

[S]

----

[M]

High-limit output scale value

※4 H.OU

[S]

----

[M]







Moving average digital filters

MAV.F

[S]

04

[M]

- ※ 1. **[S]** : Press any key among the , , .
- ※ 2. : Moves digits / , : Changes SV.
- ※ 3. Press the **[M]** key after checking/changing SV in each parameter.  
The value flashes twice and is saved. It moves to next parameter.
- ※ 4. Defaults are different by the pressure range by each model.
- ※ After entering setting group, press the **[M]** key for 3 sec. or there is no additional key operation in 30 sec., it returns to RUN mode.
- ※ : This parameter might not be displayed depending on other parameter settings.

Select input unit.

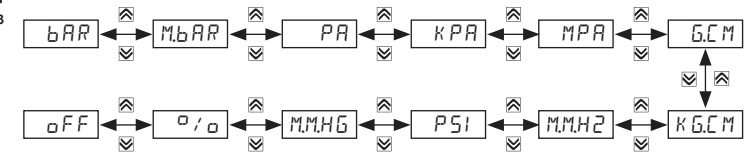

Set low-limit input value of input range.  
• Set range : within the pressure range of input type

Set high-limit input value of input range.  
• Set range : within the pressure range of input type

Select the decimal point position of display scale value.  
※ Set range is different by the pressure range.

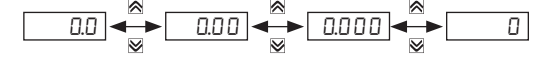

Set low-limit scale value.  
• Set range : -1999 to 9999  
※ Displayed only when selecting input unit [UNIT] as % [o/o] or OFF [OFF].

Set high-limit scale value.  
• Set range : -1999 to 9999  
※ Displayed only when selecting input unit [UNIT] as % [o/o] or OFF [OFF].

Corrects occurring error at 0% input.  
• Set range : -999 to 999

Corrects occurring error at 100% input.  
• Set range : 0.900 to 1.100

Set low-limit output scale value.  
• Set range : Within temperature range when input unit is standard pressure unit.  
Within display scale range when input unit is % or OFF.

Set high-limit output scale value.  
• Set range : Within temperature range when input unit is standard pressure unit.  
Within display scale range when input unit is % or OFF.

Set the number of moving average digital filters.  
• Set range : 01 to 16

# Standard Pressure Transmitter

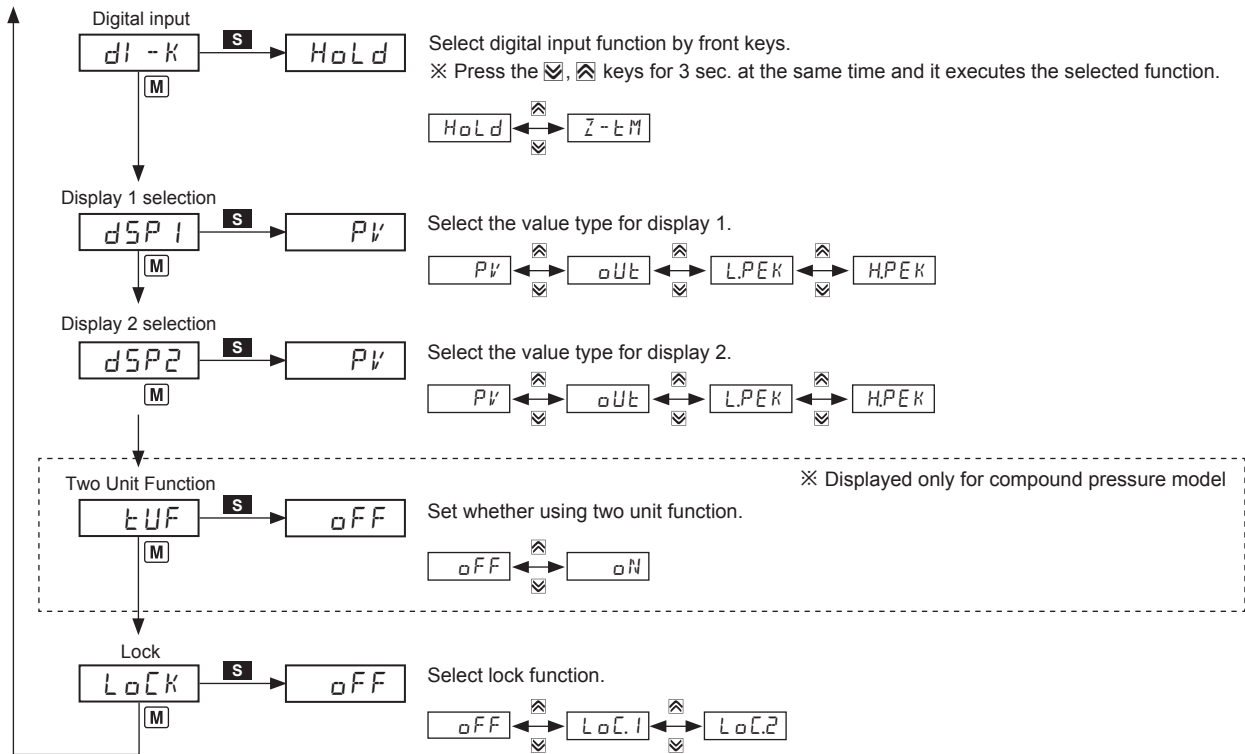

A. Recorder
B. Indicator
C. Converter
D. Controller
E. Thyristor unit
<b>F. Pressure transmitter</b>
G. Temp. transmitter
H. Accessories

TPS20
KT-302H
<b>PTF30</b>

## Proper usage

### Caution for using

- For connecting the power, use a crimp terminal (M3.5, min. 7.2 mm).
- The connection of this unit should be separated from the power line and high voltage line in order to prevent inductive noise.
- Install a power switch or a circuit breaker to supply or cut off the power.
- Switch or circuit breaker should be installed nearby users for convenient control.
- Do not use this unit near the high frequency instruments (high frequency welding machine & sewing machine, large capacity SCR controller).
- When supplying input, if HHHH or LLLL is displayed, measured input may have problem. Turn off the power and check the line.
- Installation environment
  - ① Indoor / Outdoor
  - ② Altitude max. 2,000 m
  - ③ Pollution Degree 2
  - ④ Installation Category II
- Use the verified explosion-proof electric connection (cable gland or sealing fitting) (over Ex d IIC T6 IP67).
- Use the dedicated external terminal for earth. For connecting earth, use a spring washer and earth cable which is over 4mm<sup>2</sup>.
- **We are not responsible for any damages and claims for careless. Must read the cautions for your safety and using.**
- **This explosion-proof unit is certified and the same specifications which is reported to Korea Gas Safety Corporation.**
- **If there are any problems with the unit, contact the sales office.**
- **It may cause malfunction if above instructions are not followed.**